

University of Nottingham

Department of Mechanical, Materials and Manufacturing Engineering

CONTROL: EXERCISE SHEET 0

1. Determine the Laplace transform  $F(s)$  of  $f(t)$ , if:
  - a)  $f(t) = 0.5 \frac{dx}{dt} + 4x$ , and  $x = 4$  when  $t = 0$
  - b)  $f(t) = \frac{d^2x}{dt^2} + 0.1 \frac{dx}{dt} + 3x$ , and  $x = 10$  and  $\frac{dx}{dt} = 2$  when  $t = 0$
  - c)  $f(t) = \frac{d^3x}{dt^3} + \frac{d^2x}{dt^2} + 0.1 \frac{dx}{dt} + 3x$ , and  $x = 0, \frac{dx}{dt} = 0, \frac{d^2x}{dt^2} = 0$  when  $t = 0$
2. a) Use Laplace transforms to determine the solution to the following differential equation in the time domain (i.e.  $x(t)$ )

$$\frac{d^2x}{dt^2} + 0.1 \frac{dx}{dt} + x = f(t)$$

Where  $f(t)$  is a unit step and the initial conditions are taken to be zero

- b) Determine the transfer function  $G(s)$  of the system analysed in (a) taking  $f(t)$  to be the input and  $x(t)$  to be the output of the system.
3. Determine the transfer function for the following, where  $x_i$  is the input and  $x_o$  is the output
    - a)  $\frac{d^2x_o}{dt^2} + 2\zeta\omega_n \frac{dx_o}{dt} + \omega_n^2 x_o = x_i$
    - b)  $T\dot{x}_i + x_i = x_o$
    - c)  $\frac{d^4x_o}{dt^4} + 3 \frac{d^3x_o}{dt^3} + 2 \frac{d^2x_o}{dt^2} + 2 \frac{dx_o}{dt} + x_o = 2 \frac{dx_i}{dt} + 5x_i$

Answers:

1. a)  $F(s) = (0.5s + 4)X(s) - 2$   
b)  $F(s) = (s^2 + 0.1s + 3)X(s) - 10s - 3$   
c)  $F(s) = (s^3 + s^2 + 0.1s + 3)X(s)$
2. a)  $x(t) = 1 - \frac{e^{-0.05t}}{\sqrt{1-(0.05)^2}} \sin\left(t\sqrt{1-(0.05)^2} + \cos^{-1} 0.05\right)$   
b)  $G(s) = \frac{1}{(s^2+0.1s+1)}$

CONTROL: EXERCISE SHEET 1

1. Derive expressions for the transfer functions that relate input force  $F(t)$ , and output displacement  $x(t)$ , of the spring and mass systems shown in figures 1a and 1b.

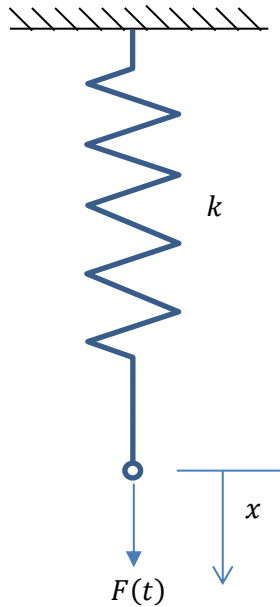

Figure 1(a). Spring System

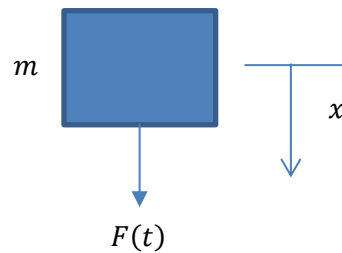

Figure 1(b). Mass System

- c) Derive an expression for the transfer function  $G(s)$  of a system that combines the spring and mass systems in parts (a) and (b).

2. Derive expressions for the transfer functions that relate input torque  $T(t)$  and output angular displacement  $\theta(t)$  of the torsional system shown in figure 2, for the following cases:
- The block has negligible mass
  - The block has a moment of inertia  $I$

Note that the torsional stiffness of the mass-less bar is  $k_T$  and the directions of  $T(t)$  and  $\theta(t)$  are similar, as shown in the figure.

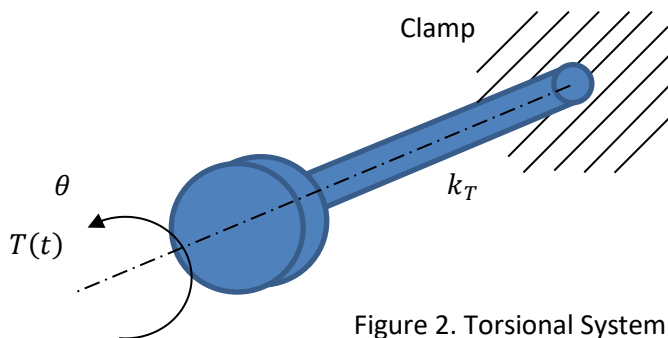

Figure 2. Torsional System

3. Derive expressions for the transfer functions that relate input  $x_i$ , and output  $x_0$ , of the spring/mass systems shown in figures 1a and 1b.

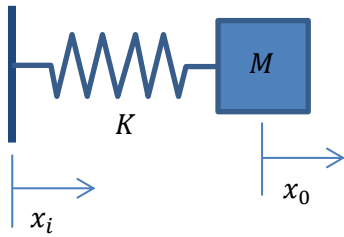

Figure 1a

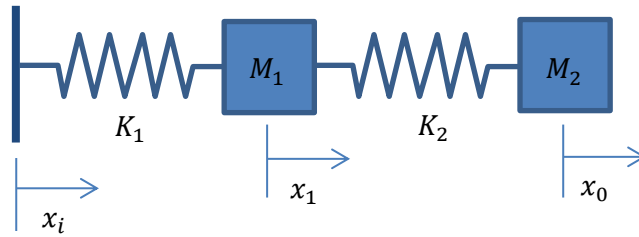

Figure 1b

4. Figure 2 shows three rigid shafts that are geared together by gears having  $N_1, N_2, N_3, N_4$  teeth as shown. Two of the shafts carry rotors having moments of inertia  $I_1$  and  $I_2$  as shown. Inertia of the gear wheels is negligible. Derive an expression for the transfer function that relates the rotation  $\theta_3$  of the output shaft to the torque  $L_1$  applied to the input shaft.

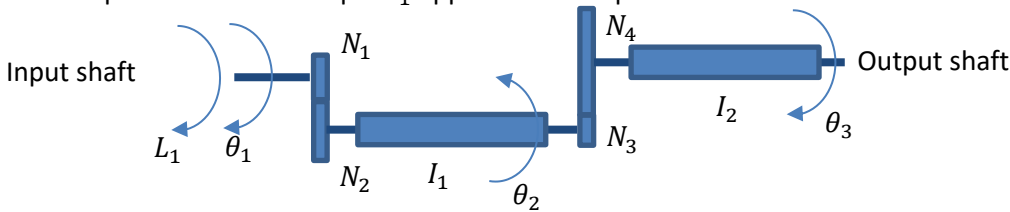

Figure 2

5. Derive expressions for the appropriate transfer functions for the tank systems shown in figures 3 a), b) and c). taking the input and output to be as indicated in the following table:

System	Input	Output
3a	$q_i$	$h_1$
3b	$q_i$	$h_2$
3c	$q_i$	$h_3$

Where  $A_1, A_2$ , and  $A_3$  are tank cross sectional areas;  $h_1, h_2$ , and  $h_3$  are the liquid heights as indicated;  $q_i, q$ , and  $q_o$  are volume flow rates; and  $R_1, R_2$ , and  $R_3$  are linearised flow resistances.

For systems 3a) and 3b) it should be noted that the volume flow rate ( $q$ ) through the restrictor tap (denoted by a cross) is given by:

$$q = \frac{h}{R}$$

where  $h$  is the height of liquid in the tank and  $R$  is the linearised flow resistance.

In system 3c) the volume flow rate  $q$  through the restrictor tap is related to the difference in liquid "head" across it by an equation of the form:

$$q = \frac{h_1 - h_2}{R_1}$$

where  $h_1$ , and  $h_2$  are the liquid heights in two adjacent, connected tanks, and  $R_1$  is the linearised flow resistance between the connected tanks.

Figure 3 a)

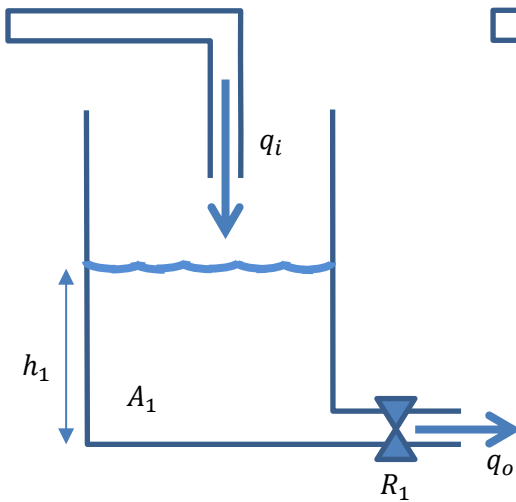

Figure 3b)

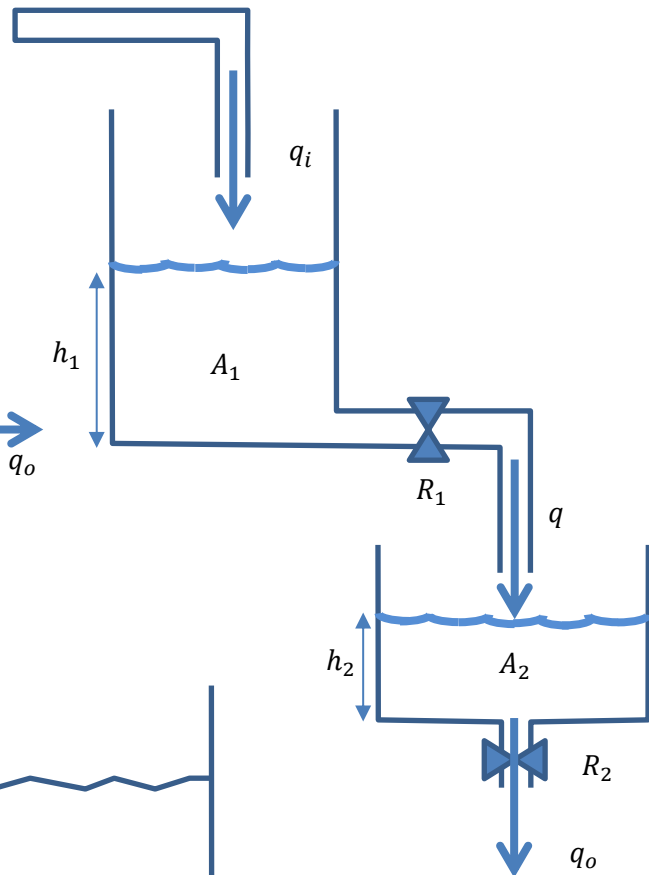
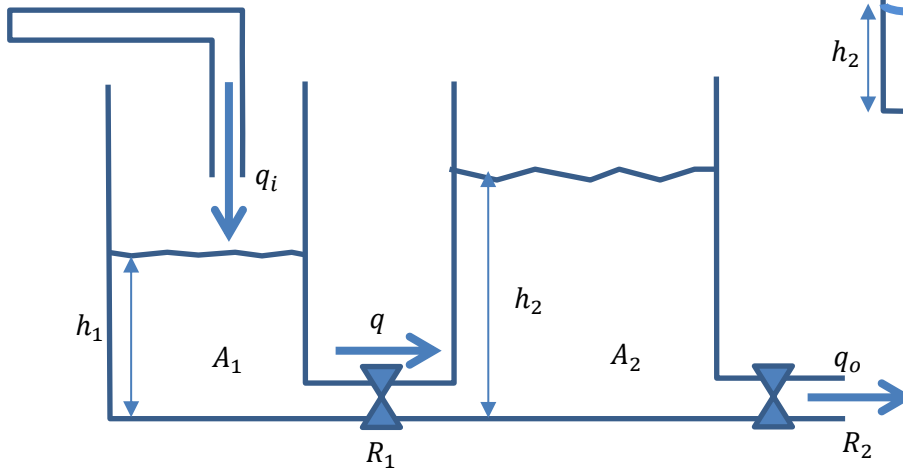

Figure 3 c)



Answers:

1. a)  $G(s) = \frac{X(s)}{F(s)} = \frac{1}{k}$   
 b)  $G(s) = \frac{X(s)}{F(s)} = \frac{1}{ms^2}$   
 c)  $G(s) = \frac{X(s)}{F(s)} = \frac{1}{ms^2+k}$

2. a)  $G(s) = \frac{X(s)}{F(s)} = \frac{1}{k_T}$   
 b)  $G(s) = \frac{X(s)}{F(s)} = \frac{1}{Is^2+k_T}$

3 a)  $\frac{X_0}{X_i} = \frac{K}{(Ms^2 + K)}$

3 b)  $\frac{X_0}{X_i} = \frac{K_1 K_2}{M_1 M_2 s^4 + s^2 (M_2 (K_1 + K_2) + M_1 K_2) + K_1 K_2}$

4  $\frac{\Theta_3}{L_1} = \frac{\left(\frac{N_2 N_4}{N_1 N_3}\right)}{\left[ I_2 + I_1 \left(\frac{N_4}{N_3}\right)^2 \right] s^2}$

5 a)  $\frac{H_1(s)}{Q_i(s)} = \frac{R_1}{(1 + Ts)}$   
 , where  $T = AR$

5 b)  $\frac{H_2(s)}{Q_i(s)} = \frac{R_2}{(1 + T_1 s)(1 + T_2 s)}$   
 , where  $T_1 = A_1 R_1$  and  $T_2 = A_2 R_2$

5 c)  $\frac{H_2(s)}{Q_i(s)} = \frac{R_2}{A_1 A_2 R_1 R_2 s^2 + (A_1 (R_1 + R_2) + A_2 R_2) s + 1}$

Sheet 2: Block Diagram Manipulations

For Questions 1-5, determine the overall transfer function for  $R(s)$  to  $C(s)$ .

1.

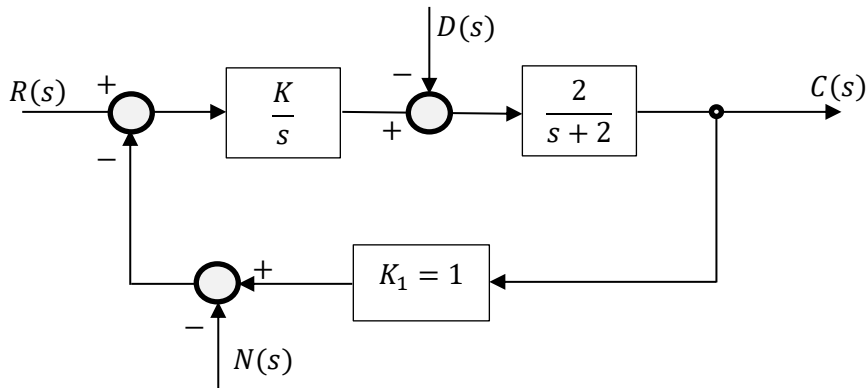

2.

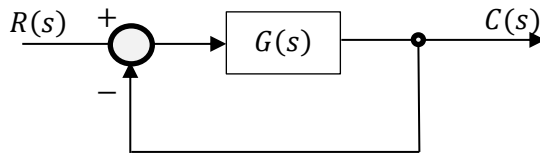

3.

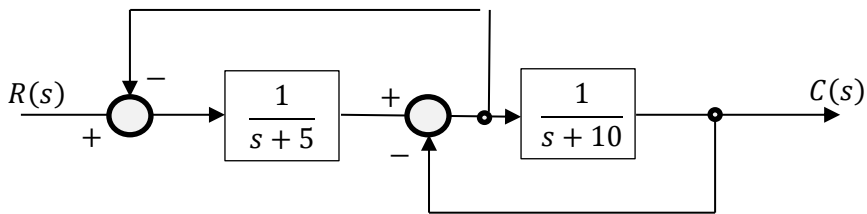

4.

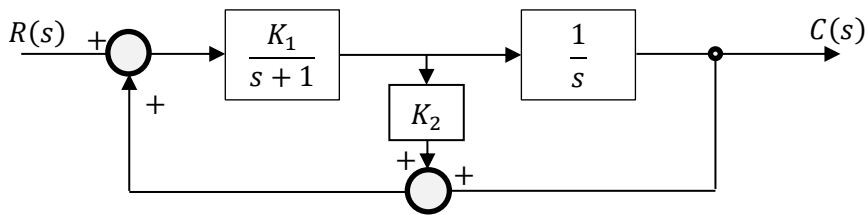

5.

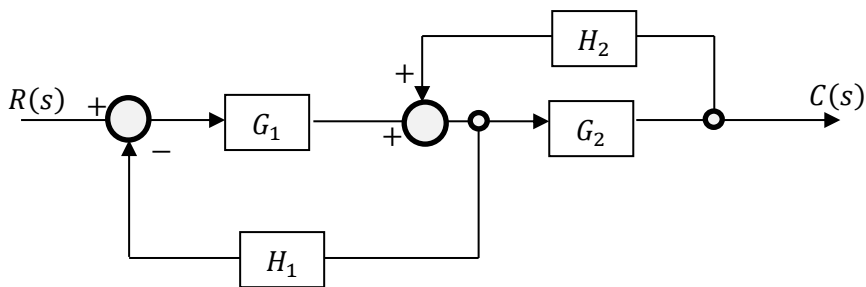

6. A system of two tanks similar to the second laboratory experiment (yet different) is shown in figure 7.

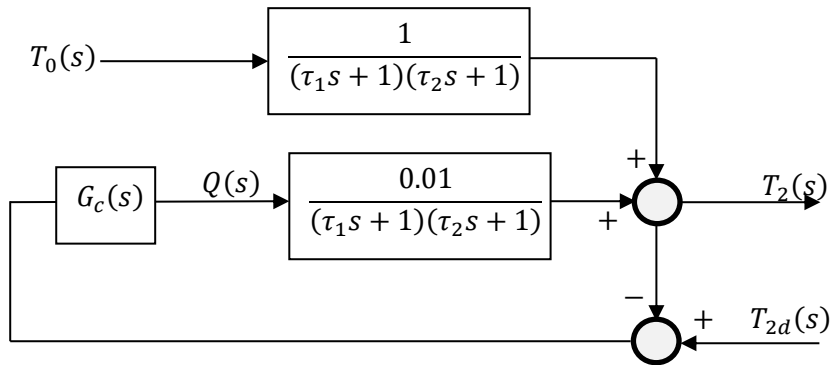

Figure 7

T represents temperature and Q is the heat input. Determine the overall transfer function for the system

$$G(s) = \frac{T_2(s)}{T_0(s)}$$

Answer:

$$G(s) = \frac{T_2(s)}{T_0(s)} = \frac{1}{(\tau_1 s + 1)(\tau_2 s + 1) + 0.01}$$

8. A control system to maintain the speed of a motor is shown in figure 8.

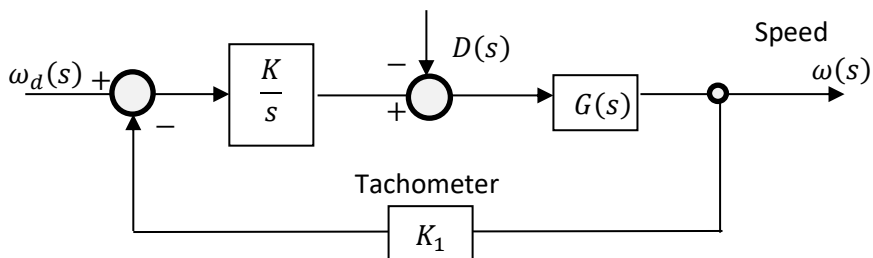

Figure 8.

The motor has a transfer function of  $G(s) = \frac{1}{s+3}$ .

Determine the overall transfer function of the system with  $\omega_d$  to  $\omega$ .

Answer:

$$G(s) = \frac{\omega(s)}{\omega_d(s)} = \frac{KG(s)}{s + K_1KG(s)}$$

1. A hydraulic servo system for positioning a large mass is shown in Figure Q1. The area of the ram (piston) is  $0.01\text{m}^2$  and the pump delivers  $0.2\text{m}^3/\text{sec}$  per metre displacement in  $y$  direction to the appropriate side of the ram piston. Determine the transfer function for the system and then calculate:
- The steady state gain and time constant of the system;
  - The error 1 second after a unit step input;
  - The steady state velocity lag when the input  $x_i$  is a ramp of uniform velocity of  $0.01\text{m}/\text{sec}$ .

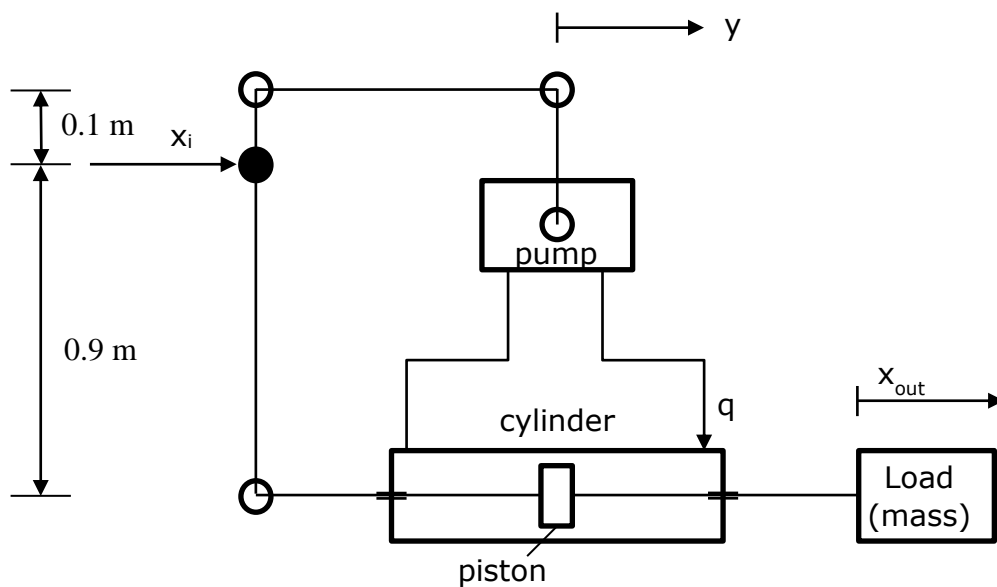

Figure Q1

2. Figure Q2 illustrates a simple system for controlling the level of liquid in a tank with uniform cross-sectional area  $A$ . The error signal  $\varepsilon$  is derived by comparing the actual height  $h$  with the desired level  $h_i$ , and is fed to a controller which drives a variable speed pump such that the controlled volumetric inflow rate  $q_i$  to the tank is given by:

$$Q_i(s) = G_C(s)\varepsilon(s)$$

where  $G_C(s)$  is the transfer function of the controller. In addition, there is an uncontrolled disturbance inflow to the tank given by  $Q_D(s)$ . The tank outflow passes through a restriction with linearised flow resistance  $R$ .

For the case when the controller is a proportional controller with gain  $K$ , such that  $G_C(s) = K$ :

- Derive the overall transfer function relating  $h$  to  $h_i$  and  $Q_D$  and show that the system is first order;
- If the tank area  $A = 2$  and the flow resistance  $R = 10$  in consistent units, find the required value of the controller gain  $K$  to give a system time constant of 5 seconds.

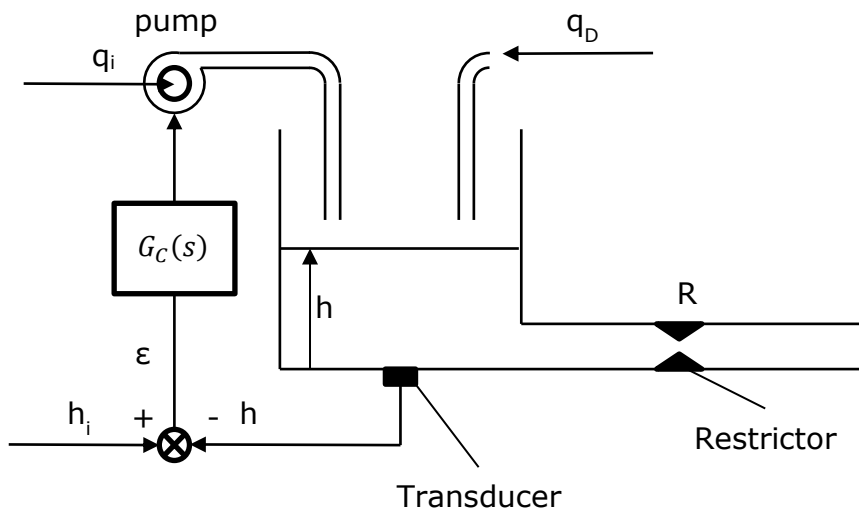

Figure Q2

Answers:

1 a) 10, 0.45 sec

b) 1.08

c) 0.045m

2 a)  $\frac{KRH_i(s)+RQ_D(s)}{1+KR+ARs}$

b)  $K=0.3$



1. Figure 1 shows a mass-damper-spring system with an applied force  $p(t)$ .
  - a. Derive the transfer function  $G(s)$  that relates the applied force  $p(t)$  to the velocity of the mass,  $v(t)$ . Let the Laplace Transform of  $p(t)$  and  $v(t)$  to be  $P(s)$  and  $V(s)$ , respectively.
  - b. Determine the steady state velocity response of the mass when a step input force is applied to the system. The magnitude of the step input is  $a$ .
  - c. Determine the steady state velocity response of the mass when a ramp input force  $p(t)=\sigma t$ , is applied to the system.

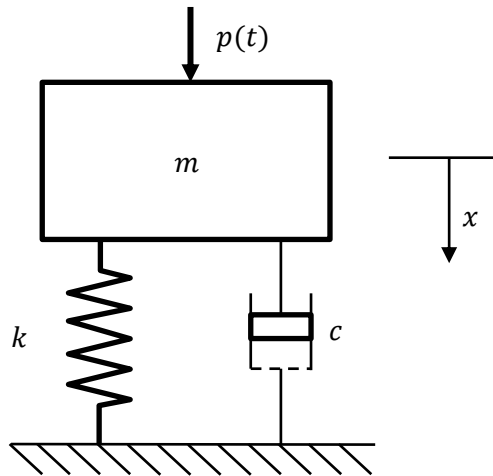

Figure 1.

2. For the system described in Q1, a control system is designed to regulate the velocity of the mass, using a proportional controller,  $K_c(s) = K$ , with a reference velocity  $V_R(t)$ . The block diagram representation of the control system is shown in Figure 2. There are two different forces applied to the mass: the disturbance force,  $F_d(t)$ , and the control force,  $F_c(t)$ .
  - a. Determine the transfer function from the reference velocity  $V_R(s)$  to the velocity of the mass  $V(s)$ . Draw the corresponding block diagram.
  - b. Determine the transfer function from the disturbance force  $F_d(s)$  to the velocity of the mass  $V(s)$ . Draw the corresponding block diagram.
  - c. What is the effect of the proportional control gain to the system damping?

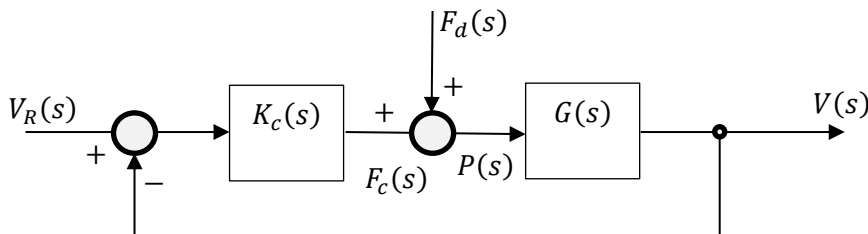

Figure 2.

3. Figure 2a shows a system for controlling the azimuth angle of a large antenna aerial. The block diagram for the system is given in figure 2b. The input signal is provided by the input potentiometer, which develops 0.05 Volts per degree change in input  $\theta_i$ . The angular position of the aerial is measured by a similar potentiometer that also generates 0.05 Volts per degree change in the aerial position  $\theta_o$ . The resulting differential error voltage is fed into the power amplifier which delivers a current to the motor with a gain of 200 Amps/Volt. The servo motor develops a torque of 0.5N/Amp and the moment of inertia of the rotating parts of the motor is 0.2 kg m<sup>2</sup>. The gear ratio of the reduction gear between the motor and the antenna turntable is 10:1 and the moment of inertia of the aerial assembly about the turntable axis is 10 kg m<sup>2</sup>.

A viscous damping torque of 100Nm/(rad s<sup>-1</sup>) opposes the rotation of the aerial.

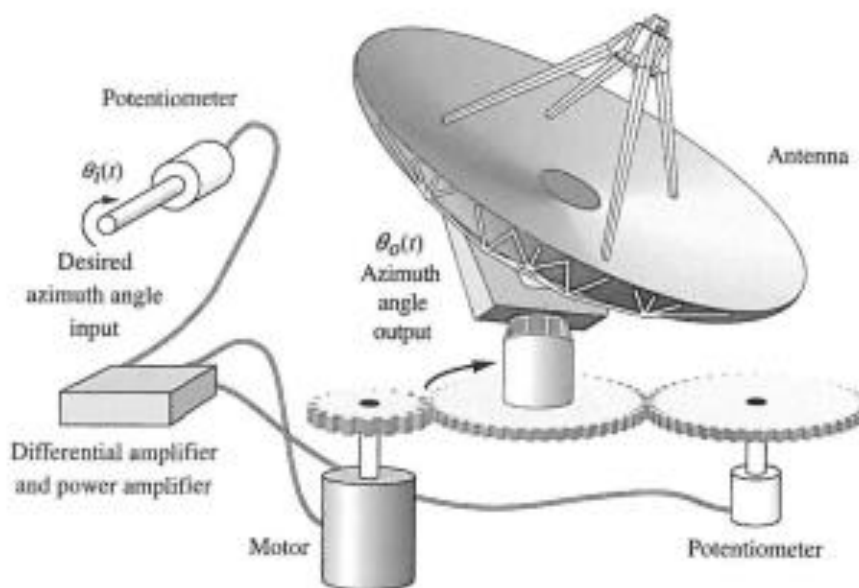

Figure 2a. Antenna Azimuth Control System (adapted from Nise, 2000)

- Draw the block diagram for the system and derive the overall transfer function relating  $\theta_o$  and  $\theta_i$ .
- Calculate the system damping ratio  $\gamma$ .
- Find the magnitude of the first overshoot which results from a step input  $\theta_i = 10^\circ$
- Find the steady state velocity error which results from the ramp input  $\theta_i = 0.1t$  radians (for  $t > 0$ ).

Answers: b)  $\gamma = 0.176$     c)  $5.8^\circ$     d)  $0.2^\circ$

**SHEET 5: STABILITY OF FEEDBACK SYSTEMS**

1. The characteristic equation of a feedback control system is

$$s^3 + (5 + K)s^2 + 7s + 18 + 9K = 0$$

- a. Determine the maximum positive value of K, below which the system is stable.
- b. Determine the frequency of oscillations at this value of K.

2. A unity feedback control system is shown in Figure Q2.

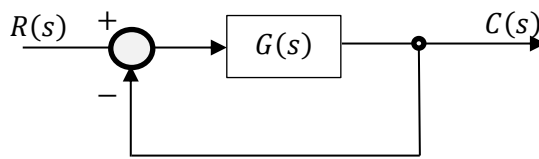

Figure Q2

Where r is a reference signal and c is the system response.

The forward loop transfer function is given by:

$$G(s) = \frac{3(s + 4)(s + 8)}{s(s + 5)^2}$$

Determine the relative stability of the system.

3. A closed loop feedback control system is shown in figure Q3.

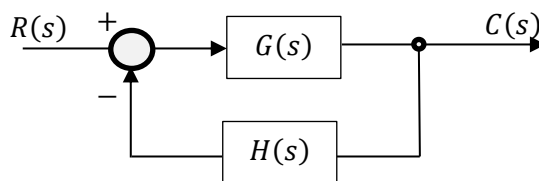

Figure Q3

Where r is a reference signal and c is a system response. The transfer functions for the forward and feedback loops are given by:

$$G(s) = \frac{K(s + 40)}{s(s + 10)} \qquad H(s) = \frac{1}{s + 20}$$

Use the Routh-Hurwitz stability criterion to determine the values of K for which the closed loop system will be stable.

4. The transfer function of a control system is as follows:

$$G(s) = \frac{1}{s^3 + 5s^2 + 20s + 6}$$

- a) Is the system stable?
- b) Use the final value theorem to calculate the unit step response of the system.

### Table of Laplace Transforms

	$f(t)$	$F(s)$
1	$\frac{df(t)}{dt}$	$sF(s) - f(0)$
2	$\frac{d^n f(t)}{dt^n}$	$s^n F(s) - s^{n-1}f(0) - s^{n-2}f'(0) \dots - f^{(n-1)}(0)$
3	$\int f(t)dt$	$\frac{1}{s}F(s)$
4	Unit impulse $\delta(t)$	1
5	Unit step 1	$\frac{1}{s}$
6	Unit ramp $t$	$\frac{1}{s^2}$
7	$e^{-at}$	$\frac{1}{s+a}$
8	$1 - e^{-at}$	$\frac{a}{s(s+a)}$
9	$t - \frac{1}{a}(1 - e^{-at})$	$\frac{a}{s^2(s+a)}$
10	$\sin(\omega t)$	$\frac{\omega}{s^2 + \omega^2}$
11	$\cos(\omega t)$	$\frac{s}{s^2 + \omega^2}$
12	$e^{-at} \sin(\omega t)$	$\frac{\omega}{(s+a)^2 + \omega^2}$
13	$e^{-at} \cos(\omega t)$	$\frac{s+a}{(s+a)^2 + \omega^2}$
14	$\frac{1}{(\omega^2 - p^2)} \left[ \sin(pt) - \frac{p}{\omega} \sin(\omega t) \right]$	$\frac{p}{(s^2 + p^2)(s^2 + \omega^2)}$
15	$\frac{1}{(\omega^2 - p^2)} [\cos(pt) - \cos(\omega t)]$	$\frac{s}{(s^2 + p^2)(s^2 + \omega^2)}$
16	$\frac{\omega}{\sqrt{1-\gamma^2}} e^{-\gamma\omega t} \sin(\omega t \sqrt{1-\gamma^2})$	$\frac{\omega^2}{s^2 + 2\gamma\omega s + \omega^2}$
17	$1 - \frac{e^{-\gamma\omega t}}{\sqrt{1-\gamma^2}} \sin(\omega t \sqrt{1-\gamma^2} + \varphi)$	$\frac{\omega^2}{s(s^2 + 2\gamma\omega s + \omega^2)}$
18	$t - \frac{2\gamma}{\omega} - \frac{e^{-\gamma\omega t}}{\omega\sqrt{1-\gamma^2}} \sin(\omega t \sqrt{1-\gamma^2} + \varphi)$	$\frac{\omega^2}{s^2(s^2 + 2\gamma\omega s + \omega^2)}$
	Where $\cos \varphi = \gamma$	